

SWING TYPE FIRE HOSEREEL (Manual)

GENERAL

"AE" Model 99-N (19mm) and 100-N (25mm) swing/recess type, manual operated fire hosereel are manufactured within a strict quality controlled environment to ISO 9001:2008 and conformed to BS EN 671-1 specifications.

The elegant design with double pivoted joints allows the installer the flexibility to fix the hosereel at the back wall or at either left or right side wall mounting. This installation flexibility greatly helps designers in deciding the appropriate size of the recessed hosereel compartment, especially in areas where space constraints are critical.

Another unique feature in the hosereel design is the "slide-in" wall mounting bracket which is a separate strong and rigid galvanised steel bracket that is initially installed onto the concrete wall without the hosereel.

The complete hosereel is then "slide in" from the top and sits in a fitting and rigid position. The water supply piping is then connected to the inlet of the hosereel.

The materials used in the manufacture of the fire hosereel are of the highest quality such as the combination of Grade 304 stainless steel, high grade aluminium alloy and/or LG2 gunmetal waterway assembly all of which are corrosion resistant and of high impact strength. The fire reel discs are pressed steel of 1.2mm thickness and epoxy/polyester powder coated. The hub is made of deep drawn galvanised steel.

FEATURES

- Elegant and compact design.
- Robust construction.
- Easy and flexible installation.
- Reliable performance with minimum maintenance.

STANDARD ACCESSORIES

- 30 metre long, EN 694 hose.
- Open/shut, 6mm orifice, Jet Stream nozzle.
- Brass stopcock or lever ball valve.*
- Zinc plated hose clamps.
- Galvanised steel nozzle holder.

OPTIONAL



- 20 & 25 metre length hoses are also available.*
- Open/Shut, 6mm and 8mm dia orifice, rotary operated spray/jet nozzle.*
- Galvanised iron union coupling fitting.

OPERATING & TEST PRESSURES

Working pressure: 12 bars (max)

Test pressure: 18 bars

APPROVAL

-  BSI Kitemark KM551497
- 
-  0620
- SETSCO Listed under PLS Class 1A (Singapore).



JET NOZZLE



SPRAY / JET NOZZLE

- Maximum length of hose according to BS EN671-1 is 30 metres.

- * As per buyer's requirement.

Note: The accessories for the Hosereel & conceptual design vary in different countries.

SWING TYPE FIRE HOSEREEL (Manual)

19mmØ x 30m

SIDE MOUNTING

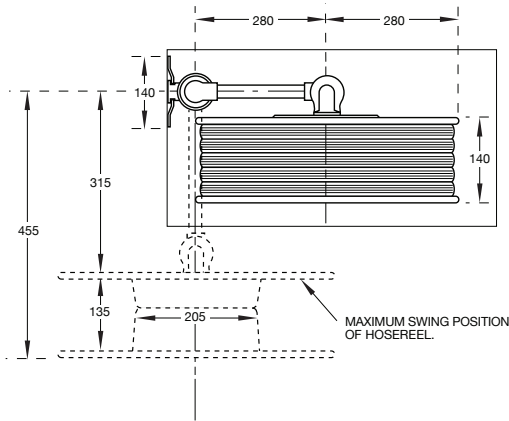

BACK MOUNTING

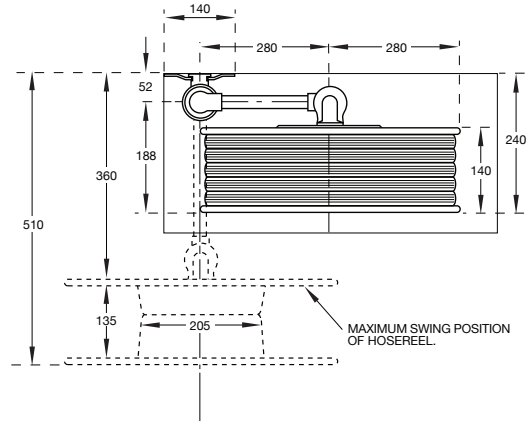

25mmØ x 30m

SIDE MOUNTING

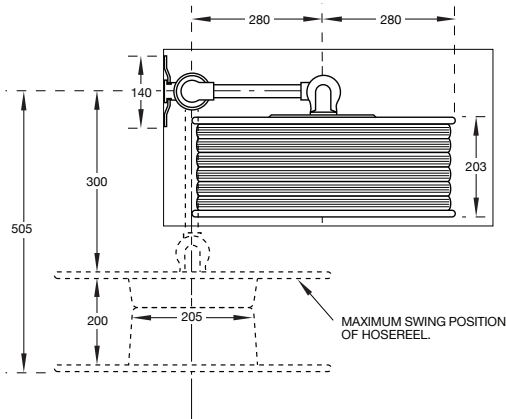

BACK MOUNTING

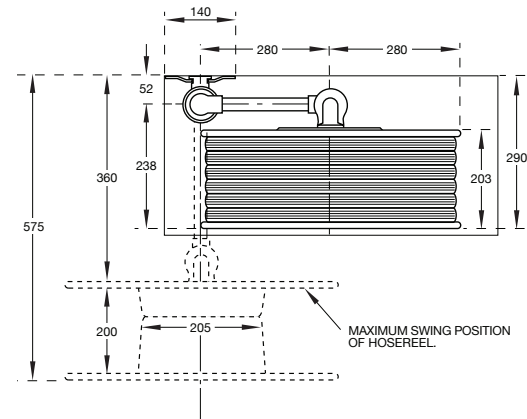

FRONT VIEW

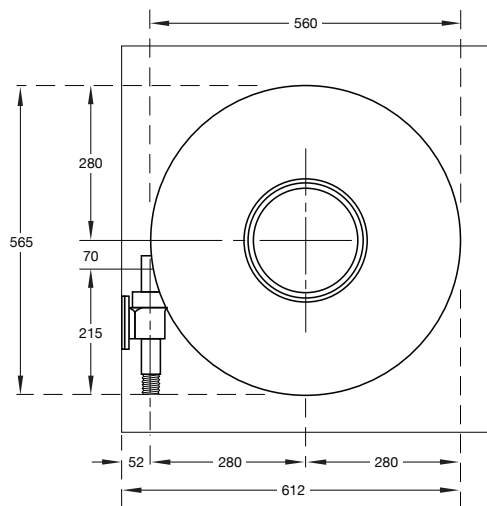

WALL MOUNTING PLATE

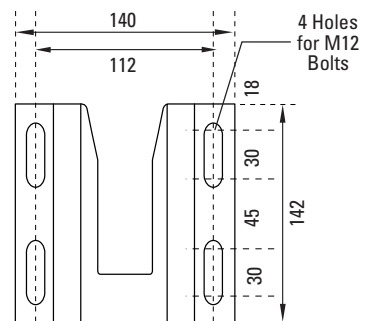

PERFORMANCE DATA

Hose size / Nozzle orifice (mm)	19/DN6		25/DN8	
Flow type	Jet	Spray	Jet	Spray
Throw Range (M)	10.3	9.4	11.2	7.9
Discharge Flowrate (L/min)	0.2MPa	28	28	45
	0.4MPa	38	42	67
	0.6MPa	46	47	76

* All dimensions shown are in millimetres.

* Due to the improvement in the design and standard, we reserve the right to change the specifications without prior notice.